

**MAINTENANCE MANUAL INDEX
REDUCED PRESSURE ASSEMBLIES
MODELS 860, 860U & 880, 880U 1/2" - 2"**

FEATURES AND OPERATING PROCEDURES

VANDALISM

GENERAL SERVICE PROCEDURES

CUT-A-WAY DRAWING

TROUBLE SHOOTING PROCEDURES

CHECK MODULE DISASSEMBLY

CHECK MODULE SEAL REPLACEMENT

CHECK MODULE RE-ASSEMBLY

RELIEF VALVE REPAIR

TESTING AND AIR GAP DRAIN INSTALLATION

EXPLODED VIEW

PARTS LIST

REPAIR KITS

FREEZE PROTECTION

WARRANTY



TABLE OF CONTENTS

| | |
|---|------------|
| Features and Operating Procedures | 2 |
| Vandalism | 2 |
| General Service Procedures | 3 |
| Cut-A-Way Drawing | 3 |
| Trouble Shooting Procedures | 4-5 |
| Check Module Disassembly | 6 |
| Check Module Seal Replacement | 6 |
| Check Module Re-Assembly | 7 |
| Relief Valve Repair | 7-8 |
| Testing | 9 |
| Air Gap Drain Installation Instructions | 9 |
| Exploded View | 10 |
| Parts List | 11 |
| Repair Kits | 12-13 |
| Freeze Protection | 15 |
| Warranty | Back Cover |

FEATURES AND OPERATING PROCEDURES

The **FEBCO Reduced Pressure Backflow Preventer Assembly** consists of two independently operating, spring loaded check valves with a pressure differential relief valve located between the two checks. The pressure drop across the first check valve is approximately 7.0 PSID with no flow. The relief valve consists of a hydraulically balanced diaphragm with the high pressure side hydraulically connected to the upstream pressure zone. The relief valve remains closed during normal operation. The low pressure side of the diaphragm is spring loaded to force the relief valve open when the pressure drop across the first check and across the diaphragm reduced to approximately 3.0 PSID. A complete assembly includes two shut-off valves and four test cocks.

VANDALISM

If the unit is installed where vandalism may be a problem, the assembly should be protected and secured. On 1/2" through 2" units the handles of shut-off valves can be removed to discourage tampering.

A protective enclosure can be installed over the unit to discourage vandals. If an enclosure is used, it should be installed so that adequate clearance is available for maintenance and testing. Consult local codes before installing any type of protective enclosure.

GENERAL SERVICE PROCEDURES

1. FEBCO backflow prevention assemblies can be serviced with standard tools and are designed for ease of maintenance. The assemblies are designed to be serviced in line, so the unit should not need to be removed from the line during servicing. **NO special tools are required.**

Suggested Tool Kit Model 860/880 (1/2" - 2")

- 1 crescent wrench
 - 1 medium standard screw driver
 - Differential pressure test kit
 - 1 medium Phillips screw driver
 - Box/open end wrench
2. The most common cause of check fouling and relief valve discharge is dirt and debris in the seating areas. The line should be flushed clean of debris before installation of the assembly. To flush the line after installation of the assembly, slowly close the inlet shut-off valve, remove the cover and spring assemblies of both check valves and open the inlet shut-off valve to allow sufficient flow of water through the assembly to clear all sand, debris, etc. from the line. If debris in the water continues to cause fouling, a strainer may be installed upstream of the assembly (check local codes).
 3. Rinse all parts with clean water before reassembly.
 4. Carefully inspect diaphragms, seals, and seating surfaces for damage or debris. If the check valve seat disc has been severely cut at the seat ring diameter, the assembly has been subjected to extremely high and repeated back pressure. Either thermal water expansion or water hammer are the most likely causes. If back pressure persists, consider installation of a pressure relief valve downstream of the assembly.
 5. Use caution to avoid damaging any guiding surfaces while handling parts. Do not force parts together. The o-ring seals used in FEBCO assemblies require only a small tightening force to insure a positive seal.
 6. Test unit after servicing in accordance with locally approved test methods to insure proper operation (see page 9 for more details).
 7. Refer to applicable exploded drawings and parts lists (pages 10-11) for visual aid information.
 8. Use food grade petroleum jelly as a lubricant as instructed in this manual.

CUT-A-WAY DRAWING

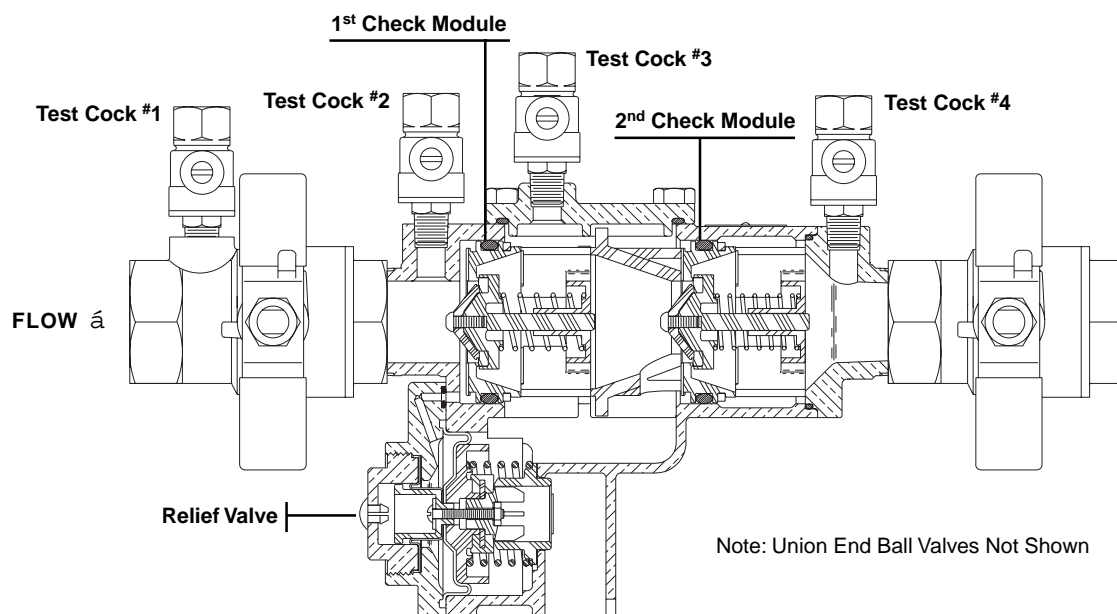

TROUBLE SHOOTING GUIDE

With Differential Pressure Gauge

| Symptom #1: | Reading: | Problem: |
|--|------------------------|---------------------------------------|
| Check Differential Across #1 Check Valve | 2 to 3 PSID | Leak in #1 or #2 check valve |
| | 6 to 8 PSID and steady | Malfunctioning pressure relief valve |
| | 2 to 7 PSID and steady | Inlet pressure fluctuating |
| Symptom #2 | Reading: | Problem: |
| Check Differential Across #1 Check Valve | 2 to 3 PSID | #1 check valve held open |
| | 6 to 8 PSID and steady | Malfunctioning pressure relief valve. |

Without Differential Pressure Gauge

| Symptom #1 and #2: | Result: | Problem: |
|--|----------------------------|--------------------------------------|
| A) Close Gate Valve #2 | If discharge stops | Leak in #2 check valve |
| | If discharge does not stop | Go to "B" |
| | Result: | Problem: |
| B) Open #4 test cock to produce a flow greater than differential relief valve discharge. | If discharge stops | Leak in #1 check valve |
| | If discharge does not stop | Malfunctioning pressure relief valve |

| Symptom #1: | Cause: | Solution: |
|---|--|--|
| <p>Continuous discharge from relief valve during NO FLOW conditions (Discharge stops with water flow).</p> <p>With this symptom, the pressure drop across the #1 check valve would be 2 to 3 PSID. If a flow of water (more than discharge) is created through the valve, the pressure drop should increase to approximately 7 PSI.</p> | A. Debris fouling #1 check valve. | Inspect and clean |
| | B. Outlet pressure higher than inlet pressure and debris fouling #2 check valve. | Inspect and Clean |
| | C. Spring stem not moving freely. | Inspect for dirt or other foreign material |
| | D. Damaged seat or seat disc. | Inspect and replace. If necessary, seat disc can be reversed in 1/2" through 2" sizes. |
| | E. Leakage at check module o-ring. | Inspect and replace seal or o-ring. |

| Symptom #2 | Cause: | Solution: |
|--|---|--|
| Intermittent discharge from relief valve during NO FLOW conditions. With the symptom, the pressure drop across the #1 check valve would be varying from about 2 to 7 PSID. | A. Inlet line pressure variations causing relief valve to discharge. | Eliminate or reduce pressure variations by installing a soft seated, spring loaded check on upstream side of device. |
| | B. Pressure surges (water hammer) causing relief valve to discharge as pressure wave passes through the zone. | Eliminate or reduce pressure surges |

TROUBLE SHOOTING GUIDE - CONTINUED

| Symptom #3 | Cause: | Solution: |
|---|--|--|
| <p>Continuous discharge from relief valve during FLOW and NO FLOW conditions.</p> <p>With this symptom, the pressure drop across the #1 check valve would be 7 PSID or more at all times.</p> | A. Seat disc dislodged from cavity in the main stem (this can be caused by pressure surges during initial filling of system lines) | Reposition disc in main stem cavity. Repressurize system slowly. |
| | B. Debris fouling the relief valve seat | Inspect and clean. |
| | C. Debris blocking the relief valve sensing passage | Inspect and clean. |
| | D. Dirt or scale jamming main stem | Inspect and clean, or replace. |
| | E. Leakage at main stem | Inspect and clean, or replace. |

| Symptom #4 | Cause: | Solution |
|--|--|---------------------------------------|
| <p>Relief valve does not open above 2.0 PSID during field testing.</p> | A. Outlet ball valve not closed completely. | Check for debris blocking ball valve. |
| | B. Plugged low pressure hydraulic passage (from "ZONE" to inner diaphragm). | Inspect and clean. |
| | C. Improper alignment of internal parts during reassembly (causing high resistance to movement). | Reassemble. |
| | D. Jammed main stem due to debris. | Clean. |

| Symptom #5: | Cause: | Solution: |
|--|--|---|
| <p>First check pressure drop is low (less than 5 PSID) during field testing.</p> | A. Debris fouling first check seat. | Inspect and clean. |
| | B. Debris fouling second seat with backpressure. | Inspect and clean. |
| | C. Inlet pressure variations causing inaccurate gauge reading. | Eliminate pressure variations. (see (symptom 2A). |
| | D. Damaged seat or seat disk. | Inspect and replace as required. |
| | E. Worn guide, bushing or stem. | Inspect and replace seal or o-ring. |

| Symptom #6 | Cause: | Solution: |
|---|---|----------------------------------|
| <p>Second check fails to hold back pressure during field testing.</p> | A. Outlet ball valve not closed completely. | Inspect and clean. |
| | B. Debris fouling second check seat. | Inspect and clean. |
| | C. Damaged seat or seat disk. | Inspect and replace if required. |
| | D. Worn guide, bushings or stem. | Inspect and replace if required. |

CHECK MODULE DISASSEMBLY

1. Slowly close inlet and outlet ball valves. Bleed residual pressure by opening #2, #3, and #4 test cocks. Allow the test cocks to remain open until the reassembling is completed. Test cock #1 should remain closed.
2. Remove the cover bolts (item 21) using the appropriate size wrench.
3. Remove spacer (item 8) by grasping the flanged end of the spacer and pulling straight up.
4. Remove the inlet check assembly by pulling it in the direction of flow out from the body bore until it is completely exposed then lift out of the body.
5. Remove the outlet check assembly by placing the tip of a medium size flat nose screw driver in the slot of the seat (item 3) and prying the check assembly back until the red o-ring (item 3.1) is exposed. Then, using your fingers, pull it out from the body bore until it is completely exposed then lift out of the body.

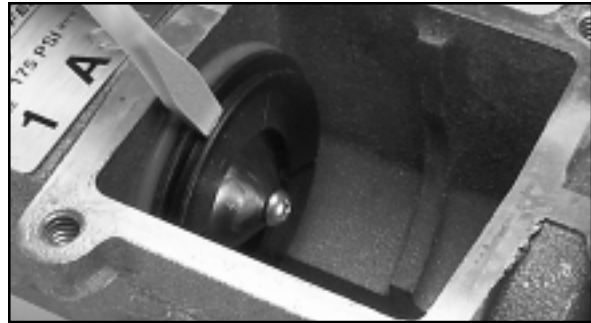
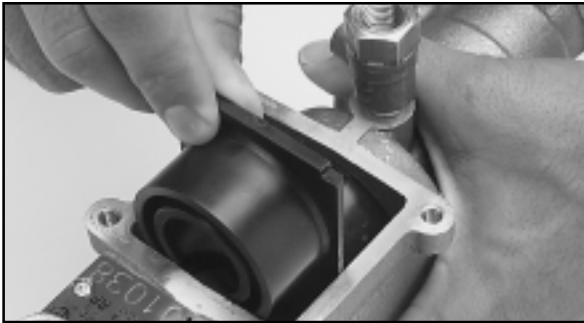

CHECK MODULE SEAL REPLACEMENT

Both check assemblies are disassembled and reassembled in the same manner. To service the checks you may replace the check modules with new ones by using check module assembly kits available from FEBCO. Or, you may also replace the rubber components in the check modules by using the replacement rubber parts kits available from FEBCO. For details on parts and kits please see pages 10 - 13.

1. To disassemble, grasp the seat section (item 3) in one hand and the guide section (item 7) in the other hand and then rotate in a counter clock wise direction (approx. $\frac{1}{8}$ turn) until the two parts disengage.



water and replace the old rubber disc with new rubber disc. If the rubber disc is not damaged it can be reversed and reinstalled when a new disc is not available. Rinse all other internal components with clean water. Replace disc retainer and secure with retaining screw (item 5.2).



2. Remove retaining screw (item 5.2) and disc retainer (item 5.1) so the rubber disc is fully exposed. Carefully pry out the rubber disc from poppet. Be careful not to damage the poppet when removing the disc. Rinse poppet in clean
3. Reassemble check module in the reverse manner as indicated in above. When reassembling the check module be sure to insert the poppet stem into the guide hole and keep fingers clear of the slots in the module.

CHECK MODULE RE-ASSEMBLY

Use reverse procedure for assembly with the following special instructions.

1. Inspect the check module o-ring (item 3.1) for damage and replace if necessary. To ease assembly, apply a thin coating of FEBCO factory supplied petroleum jelly (food grade) to the o-ring (item 3.1) prior to installing in body. **CAUTION:** Excess lubricant may cause foreign debris to collect on internal components which could foul the check assembly and result in a test failure.
2. The word **INLET** is inscribed on the end of each module. That end should face the inlet of the valve.



3. **On Reduced Pressure Assembly Model 860, make sure the check assembly with the heavy**

duty spring is inserted in the inlet bore of the body (1st check position). The check assembly with the weaker spring must be installed in the outlet bore of the body (2nd check position).

4. When replacing spacer (item 8) between the two check assemblies be sure that the flanged end of the spacer is touching the back side of the inlet check assembly so that the cover will fit properly. Next, replace cover making sure #3 test cock is on the upstream side. Do not over tighten cover bolts (Approximately 35 inch-pounds is sufficient).
5. After reassembling, close test cock #2, #3 and #4 (test cock #1 should already be closed), slowly open inlet ball valve. Bleed air from the unit by opening and closing test cock #2, then #3 and finally #4. **NOTE:** During the bleeding process on the Reduced Pressure Assembly Model 860 the relief valve may discharge a high volume of water until all test cocks have been closed and pressure stabilized.
6. Check for external leaks and repair if necessary. Slowly open outlet ball valve.
7. Test assembly in accordance with the locally approved test methods.

RELIEF VALVE REPAIR

NOTE: Discharge from the relief valve assembly may not indicate a relief valve failure. The relief valve will discharge water when the mainline check valves become fouled with foreign debris. See Trouble Shooting Guide for more information **BEFORE** disassembling the relief valve.

1. Slowly close inlet and outlet ball valves. Bleed off air from the unit by opening and closing test cock #2, then #3, and finally #4. Test cock #1 should remain closed.
2. Loosen brass cylinder in center of relief valve cover (item 18) by unscrewing $\frac{1}{4}$ turn (Counter-clockwise). Remove the relief valve cover bolts (item 21) and relief valve cover (item 19).
3. The internal relief valve assembly module will be attached to the relief valve cover. Unscrew the brass cylinder and remove from cover. Grasp the outer diameter of the large outer diaphragm (item 15) and pull away from the cover until the small outer diaphragm (item 16) comes out through the

relief valve cover hole and is completely separated from the relief valve cover. Discard old internal relief valve assembly module. Remove the plastic slip rings (item 18.1) and discard. Slide out the seat ring (item 12) and seat gasket ring (item 12.1) from the relief valve body and discard.

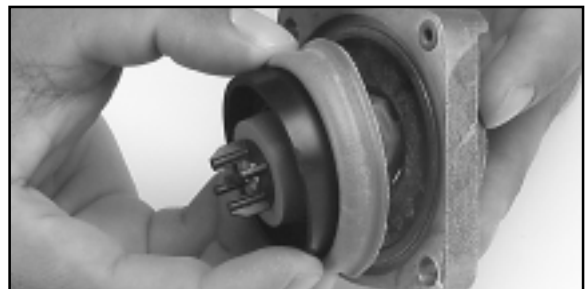

RELIEF VALVE REPAIR - CONTINUED

4. Apply a thin film of petroleum jelly (food grade), supplied in the repair kit to both sides of the new seat gasket ring (item 12.1) and slide it on the short end of the new seat ring (item 12). Slide the short end of the new seat ring into the hole of the relief valve body. (The adhesion from the lubricant will hold the seat ring in place during the rest of the assembly process.)
5. Before installing the new internal relief valve assembly module, apply a thin coating of petroleum jelly (food grade) to both sides one of the slip rings (item 18.1) and insert it into the top of the relief valve cover. Install the new internal relief valve assembly module by grasping the outside of the outer diaphragm in one hand and the smaller diaphragm in the other hand. Then pull upward gently on the small outer diaphragm (item 16) so that it forms the shape of a tulip. Hold the small diaphragm so that it maintains this "tulip" shape while sliding it through the relief valve cover hole and plastic diaphragm gasket.

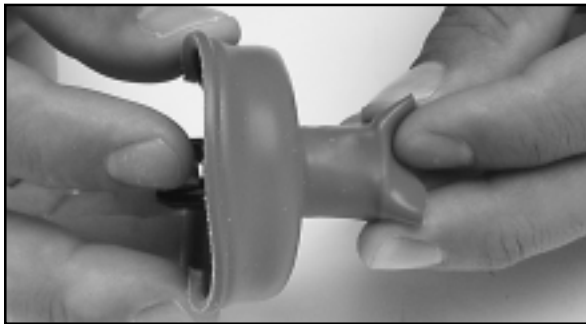

6. Apply a thin coat of petroleum jelly (food grade) to both sides of the slip ring (item 18.1) and place it over the top of the small diaphragm making sure the outer diaphragm (item 16) is not folded or creased under the slip ring. Push the slip ring down flat until the adhesion from the grease holds the small diaphragm in place. Thread the brass cylinder (item 18) into the relief valve cover and hand tighten.



7. Replace o-ring (item 20) in relief valve cover. Make sure the round bead on the large diaphragm is properly seated in the counterbore of the relief valve cover. Position spring (item 13) over the seat ring in the relief valve body and hold in place while inserting the guide end (item 23) of the relief valve assembly module and relief valve cover. Position the assembly so the o-ring aligns with the sensing hole in the body and the guide slides into the seat ring. Replace relief valve cover bolts and tighten to approximately 35 inch pounds. **Do not over tighten.** Tighten the brass cylinder (item 18) in the relief valve cover to approximately 30 feet pounds of torque. **Do not over tighten.**

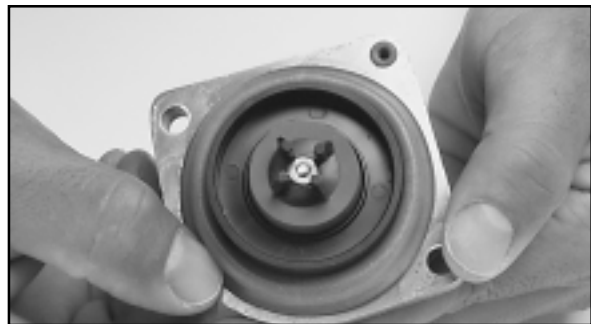

8. After reassembly, with all test cocks closed, slowly open inlet ball valve and bleed air from the unit by opening and closing test cock #2, then #3 and finally #4. NOTE: During the bleeding process the relief valve may discharge a high volume of water until all test cocks have been closed and pressure has been stabilized.
9. Check for external leaks and repair if necessary. Slowly open outlet ball valve.
10. Test assembly in accordance with the locally approved test method.

TESTING

All mechanical devices should be inspected on a regular basis to ensure they are working correctly. The assembly should be tested at time of initial installation, after servicing or maintenance, and at least annually thereafter. Acceptable test procedures are published by Foundation for Cross Connection Control and Hydraulic Research at the University of Southern California (USC), The American Water Works Association (AWWA), The American Society of Sanitary Engineering (ASSE Series 5000) and the Canadian Standards Association (CAN/CSA B64•10). Please consult the regulatory authority in your area for more specific information.

AIR GAP DRAIN INSTALLATION INSTRUCTIONS

1. Before installation check local codes. This type of drain may not be approved for use in some areas.

CAUTION: This drain is intended to catch moderate relief valve discharges due to line pressure fluctuations and minor check valve fouling. Under certain conditions relief valves can discharge water at rates greater than the drain capacity.

2. If installed indoors, the assembly should be installed near a floor drain sized to adequately handle discharge.
3. After installation of backflow assembly and piping, attach drain funnel to relief as shown, using self tapping screws provided in kit to join drain funnel halves together, making sure that the slots in the drain funnel are located over tabs on relief valve port.

NOTE: Discharge of drain funnel is a slip fit design. Drain funnel was not deigned to, nor is it able to support drainpipe weight.

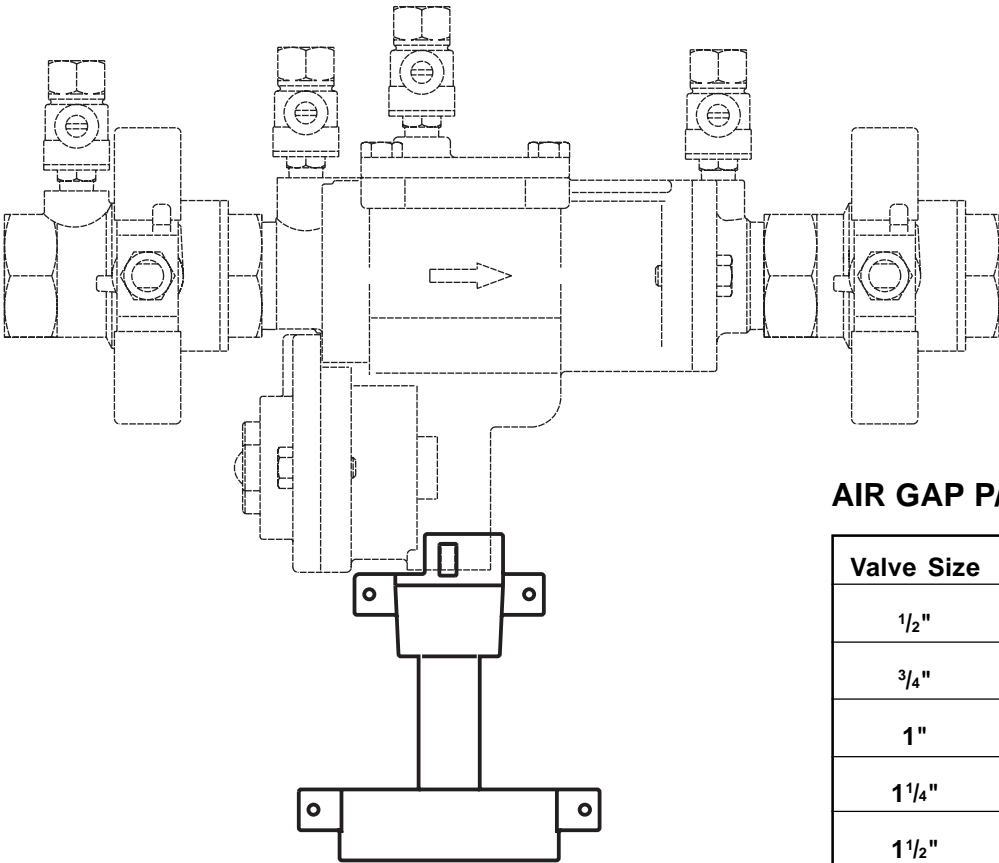

AIR GAP P/N

| Valve Size | P/N |
|------------|---------|
| 1/2" | 905-358 |
| 3/4" | 905-358 |
| 1" | 905-358 |
| 1 1/4" | 905-359 |
| 1 1/2" | 905-359 |
| 2" | 905-359 |

EXPLODED VIEW

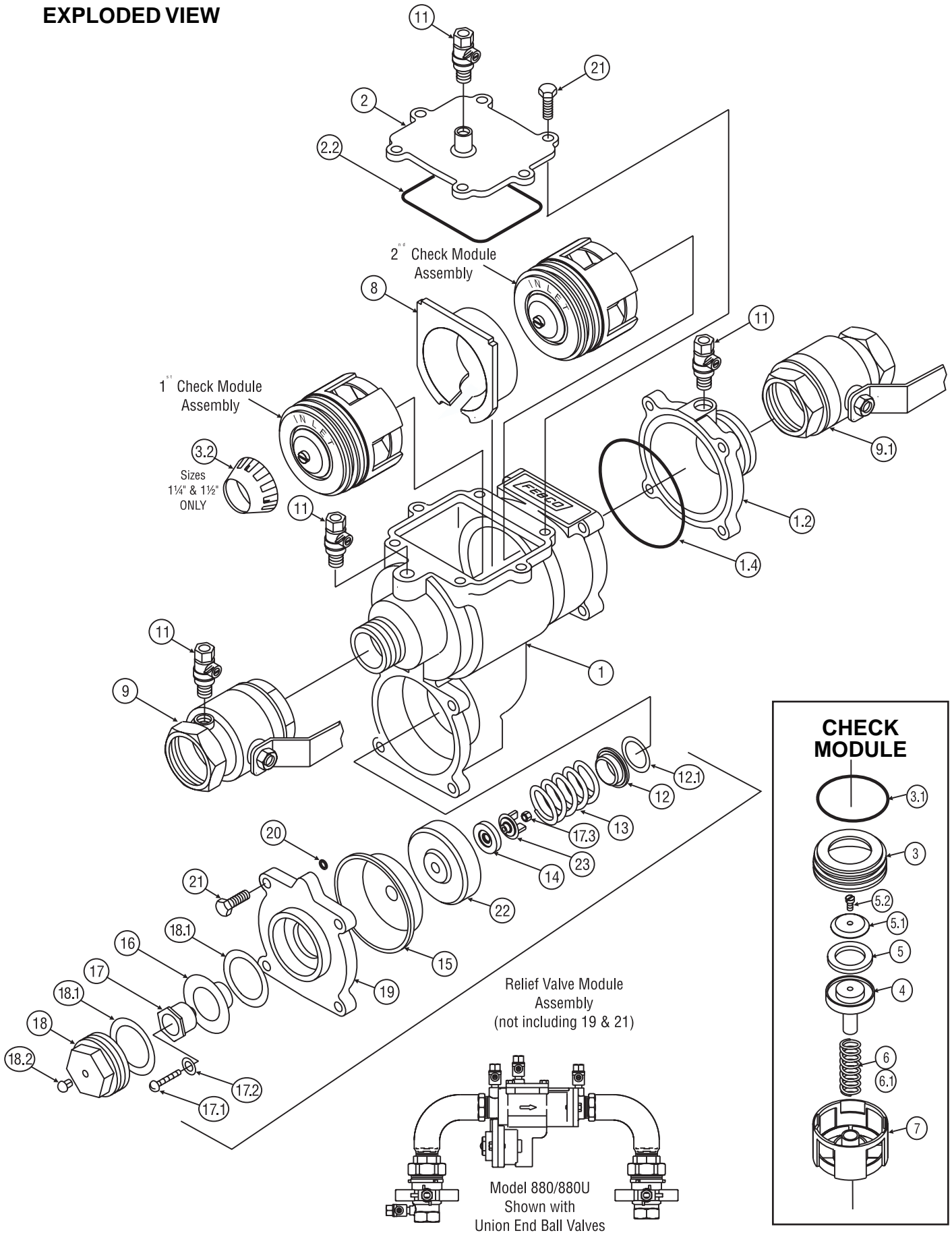

PARTS LIST 860 /860U / 880 / 880U

| Item | Description | Qty. | 1/2 | 3/4 | 1 | 1 1/4 | 1 1/2 | 2 |
|------|------------------------------|------|----------|-----------|----------|----------|----------|----------|
| 1 | Body | 1 | 110135 | 110033 | 110034 | 110137 | 110030 | 110028 |
| 1.2 | Tailpiece | 1 | 110127 | 110040 | 110039 | 110138 | 110138 | 110037 |
| 1.4 | O-Ring | 1 | 39603070 | 39603070 | 39603370 | 39604370 | 39604370 | 39604370 |
| 2 | Cover | 1 | 110041 | 110041 | 110035 | 110026 | 110026 | 110026 |
| 2.2 | O-Ring | 1 | 39622470 | 396622470 | 39622970 | 39624070 | 39624070 | 39624070 |
| 3 | Seat | 2 | 500393 | 500393 | 500373 | 500358 | 500358 | 500358 |
| 3.1 | O-Ring | 2 | 39612670 | 39612670 | 39622470 | 39633770 | 39633770 | 39633770 |
| 3.2 | Inlet Ring (1 1/4" & 1 1/2") | 1 | N/A | N/A | N/A | 500397 | 500397 | N/A |
| 4 | Poppet | 2 | 500394 | 500394 | 500374 | 500357 | 500357 | 500357 |
| 5 | Seat Disc | 2 | 410127 | 410127 | 410134 | 410128 | 410128 | 410128 |
| 5.1 | Disc Retainer | 2 | 500396 | 500396 | 500391 | 500384 | 500384 | 500384 |
| 5.2 | Round HD Screw | 2 | 51653203 | 51653203 | 51653203 | 51951304 | 51951304 | 51951304 |
| 6 | Spring | 1 | 630177 | 630177 | 630173 | 630169 | 630169 | 630169 |
| 6.1 | Spring (860 2nd Check) | 1 | 630178 | 630178 | 630174 | 630170 | 630170 | 630170 |
| 7 | Guide | 2 | 500395 | 500395 | 500375 | 500356 | 500356 | 500356 |
| 8 | Retainer Spacer | 1 | 500392 | 500392 | 500376 | 500366 | 500366 | 500366 |
| 9* | Ball Valve Tapped | 1 | 781244 | 781053 | 781054 | 781055 | 781056 | 781057 |
| | Union End BV Tapped | 1 | 781287 | 781288 | 781289 | 781290 | 781291 | 781292 |
| 9.1* | Ball Valve | 1 | 781047 | 781048 | 781049 | 781050 | 781051 | 781052 |
| | Union End Ball Valve | 1 | 781293 | 781294 | 781295 | 781296 | 781297 | 781298 |
| 11 | Test Cock | 4 | 781074 | 781074 | 781074 | 781075 | 781075 | 781075 |
| 12 | Seat Ring - RV | 1 | 500378 | 500378 | 500378 | 500368 | 500368 | 500368 |
| 12.1 | Gasket Ring - RV | 1 | 410137 | 410137 | 410137 | 410131 | 410131 | 410131 |
| 13 | Spring - RV | 1 | 630175 | 630175 | 630175 | 630171 | 630171 | 6301713 |
| 14 | Seat Disc - RV | 1 | 420021 | 420021 | 420021 | 420020 | 420020 | 420020 |
| 15 | Diaphragm - RV | 1 | 400140 | 400140 | 400140 | 400138 | 400138 | 400138 |
| 16 | Outer Diaphragm - RV | 1 | 400139 | 400139 | 400139 | 400130 | 400130 | 400130 |
| 17 | Small Piston - RV | 1 | 500380 | 500380 | 500380 | 500370 | 500370 | 500370 |
| 17.1 | Round HD Screw - RV | 1 | 51653107 | 51653107 | 51653107 | 51653310 | 51653310 | 51653310 |
| 17.2 | Washer - RV | 1 | 360091 | 360091 | 360091 | 240143 | 240143 | 240143 |
| 17.3 | Hex Nut - RV | 1 | 52153100 | 52153100 | 52153100 | 52153300 | 52153300 | 52153300 |
| 18 | Cylinder - RV | 1 | 200834 | 200834 | 200834 | 200833 | 200833 | 200833 |
| 18.1 | Slip Ring Cylinder - RV | 2 | 340107 | 340107 | 340107 | 340105 | 340105 | 340105 |
| 18.2 | Slide (Plug) - RV | 1 | 781225 | 781225 | 781225 | 781225 | 781225 | 781225 |
| 19 | Cover - RV | 1 | 110036 | 110036 | 110036 | 110029 | 110029 | 110029 |
| 20 | O-Ring - RV | 1 | 39600670 | 39600670 | 39600670 | 39600670 | 39600670 | 39600670 |
| 21 | Hex HD Capscrew | 14 | 51151306 | 51151306 | 51151306 | 51151406 | 51151406 | 51151406 |
| 22 | Large Piston - RV | 1 | 500377 | 500377 | 500377 | 500367 | 500367 | 500367 |
| 23 | Guide - RV | 1 | 500382 | 500382 | 500382 | 550372 | 550372 | 550372 |

*Union End Ball Valve Not Shown.

REPAIR KITS: 860 /860U / 880 / 880U

How to order parts and Repair Kits

1. Locate item number and kit number in this maintenance manual.
2. Verify the size of the valve the parts are to be used on.
3. Provide full model number located on I.D. plate.
4. Give kit number.
5. A serial number (located on the I.D. plate) will assist in ordering the proper kits.
6. Contact your local FEBCO Parts Distributor.

| Rubber Parts Kit | | 1/2 | 3/4 | 1 | 1 1/4 | 1 1/2 | 2 |
|---------------------------|------------------|---------|---------|-------------------------|---------|---------|---------|
| Part No. | | 905-355 | 905-355 | 905-356 | 905-357 | 905-357 | 905-357 |
| All Sizes Include: | | | | | | | |
| Item | Description | Qty. | Item | Description | Qty. | | |
| 2.2 | O-Ring | 1 | 14 | Seat Disc - RV | 1 | | |
| 3.1 | O-Ring | 1 | 15 | Diaphragm - RV | 1 | | |
| 5 | Seat Disc | 2 | 16 | Outer Diaphragm - RV | 1 | | |
| 12 | Seat Ring - RV | 1 | 18.1 | Slip Ring Cylinder - RV | 2 | | |
| 12.1 | Gasket Ring - RV | 1 | 20 | O-Ring - RV | 1 | | |

| Check Module Rubber Kit | | 1/2 | 3/4 | 1 | 1 1/4 | 1 1/2 | 2 |
|---------------------------|-------------|---------|---------|-------------|---------|---------|---------|
| Part No. | | 905-342 | 905-342 | 905-343 | 905-344 | 905-344 | 905-344 |
| All Sizes Include: | | | | | | | |
| Item | Description | Qty. | Item | Description | Qty. | | |
| 2.2 | O-Ring | 1 | 5 | Seat Disc | 2 | | |
| 3.1 | O-Ring | 2 | | | | | |

| Relief Valve Rubber Kit | | 1/2 | 3/4 | 1 | 1 1/4 | 1 1/2 | 2 |
|---------------------------|------------------|---------|---------|-------------------------|---------|---------|---------|
| Part No. | | 905-345 | 905-345 | 905-345 | 905-346 | 905-346 | 905-346 |
| All Sizes Include: | | | | | | | |
| Item | Description | Qty. | Item | Description | Qty. | | |
| 12 | Seat Ring - RV | 1 | 16 | Outer Diaphragm - RV | 1 | | |
| 12.1 | Gasket Ring - RV | 1 | 18.1 | Slip Ring Cylinder - RV | 2 | | |
| 14 | Seat Disc - RV | 1 | 20 | O-Ring - RV | 1 | | |
| 15 | Diaphragm - RV | 1 | | | | | |

REPAIR KITS - CONTINUED

| Single Poppet Kit | | $\frac{1}{2}$ | $\frac{3}{4}$ | 1 | $1\frac{1}{4}$ | $1\frac{1}{2}$ | 2 |
|---------------------------|-------------|---------------|---------------|----------------|----------------|----------------|----------|
| Part No. | | 905-339 | 905-339 | 905-340 | 905-341 | 905-341 | 905-341 |
| All Sizes Include: | | | | | | | |
| Item | Description | Qty. | Item | Description | Qty. | | |
| 4 | Poppet | 1 | 5.1 | Disc Retainer | 1 | | |
| 5 | Seat Disc | 1 | 5.2 | Round HD Screw | 1 | | |

| 1st Check Module Assembly | | $\frac{1}{2}$ | $\frac{3}{4}$ | 1 | $1\frac{1}{4}$ | $1\frac{1}{2}$ | 2 |
|---|-------------|---------------|---------------|----------------|----------------|----------------|----------|
| Part No. | | 905-348 | 905-348 | 905-350 | 905-352 | 905-352 | 905-352 |
| All Sizes Include: | | | | | | | |
| Item | Description | Qty. | Item | Description | Qty. | | |
| 3 | Seat | 1 | 5.1 | Disc Retainer | 1 | | |
| 3.1 | O-Ring | 1 | 5.2 | Round HD Screw | 1 | | |
| 4 | Poppet | 1 | 6.1 | Spring | 1 | | |
| 5 | Seat Disc | 1 | 7 | Guide | 1 | | |

| 2nd Check Module Assembly | | $\frac{1}{2}$ | $\frac{3}{4}$ | 1 | $1\frac{1}{4}$ | $1\frac{1}{2}$ | 2 |
|---|-------------|---------------|---------------|----------------|----------------|----------------|----------|
| Part No. | | 905-347 | 905-347 | 905-349 | 905-351 | 905-351 | 905-351 |
| All Sizes Include: | | | | | | | |
| Item | Description | Qty. | Item | Description | Qty. | | |
| 3 | Seat | 1 | 5.1 | Disc Retainer | 1 | | |
| 3.1 | O-Ring | 1 | 5.2 | Round HD Screw | 1 | | |
| 4 | Poppet | 1 | 6 | Spring | 1 | | |
| 5 | Seat Disc | 1 | 7 | Guide | 1 | | |

| Relief Valve Module Assembly Kit | | $\frac{1}{2}$ | $\frac{3}{4}$ | 1 | $1\frac{1}{4}$ | $1\frac{1}{2}$ | 2 |
|---|----------------------|---------------|---------------|-------------------------|----------------|----------------|----------|
| Part No. | | 905-353 | 905-353 | 905-353 | 905-354 | 905-354 | 905-354 |
| All Sizes Include: | | | | | | | |
| Item | Description | Qty. | Item | Description | Qty. | | |
| 12 | Seat Ring - RV | 1 | 17.1 | Round HD Screw - RV | 1 | | |
| 12.1 | Gasket Ring - RV | 1 | 17.2 | Washer - RV | 1 | | |
| 13 | Spring - RV | 1 | 17.3 | Hex Nut - RV | 1 | | |
| 14 | Seat Disc - RV | 1 | 18.1 | Slip Ring Cylinder - RV | 2 | | |
| 15 | Diaphragm - RV | 1 | 20 | O-Ring - RV | 1 | | |
| 16 | Outer Diaphragm - RV | 1 | 22 | Large Piston -RV | 1 | | |
| 17 | Small Piston - RV | 1 | 23 | Guide - RV | 1 | | |

FREEZE PROTECTION

The backflow prevention assembly may be subject to damage if the internal water is allowed to freeze. The unit must be protected from freezing using a heated enclosure, insulation using heat tape, or other suitable means. The unit must always be accessible for testing and maintenance. If the system will be shut down during freezing weather, use the following procedures to drain internal passages.

Ball Valve Shut-Off Draining Procedure

If the assembly has been installed with ball valve shut-off valves, they must also be properly drained to prevent freeze damage. After draining procedure has been completed on the backflow prevention assembly, position all ball valve shut-offs and test cocks in a half open/half closed (45 degree) position.

Open the ball valve approximately 45 degrees while draining the pipeline and assembly to allow water between the ball valve and valve body to drain. Leave the ball valve in this position for the winter to prevent freeze damage.

The ball valve must be fully closed before the system is repressurized. **OPEN AND CLOSE BALL VALVES SLOWLY TO PREVENT DAMAGE TO THE SYSTEM CAUSED BY WATER HAMMER.**

Main Valve Draining Procedure (1/2" - 2")

1. Close the main shut-off valve.
2. Open the inlet drain.
3. Open the inlet and outlet ball valves 45 degree (half open, half closed).
4. Open all testcocks.
5. Open the outlet drain.
6. Remove the cover and inlet check module until all water inside valve drains back out through inlet drain.
7. If you *blowout* the piping downstream of the backflow assembly using compressed air: Connect the air supply to the outlet drain and close the outlet ball valve. After clearing the system with air, partially open the outlet ball valve. Leave all drain valves, testcocks, and ball valves in half open/half closed position for the winter.
8. (RP UNITS ONLY) Loosen the relief valve cover to drain. Tighten when draining is complete.

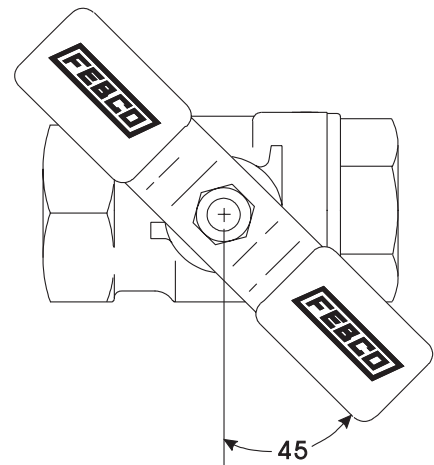

FEBCO PERFORMANCE, VALUE, AND QUALITY

FEBCO MasterSeries® (2½" - 10")

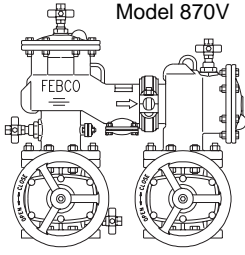
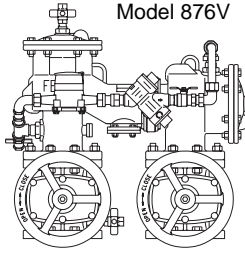
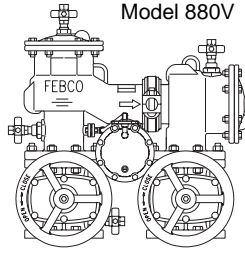
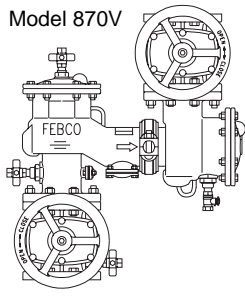
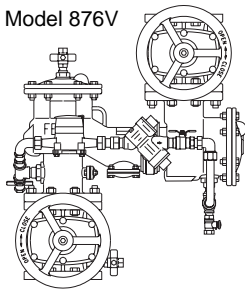
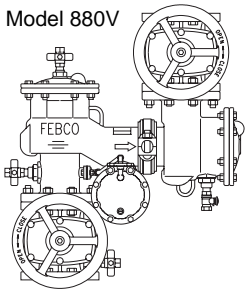
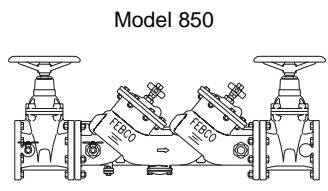
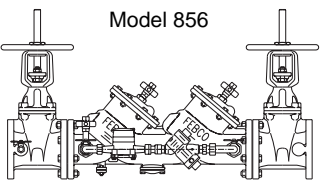
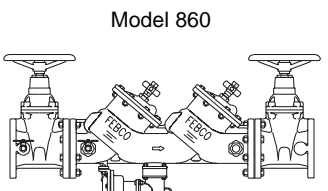
| | Double Check Assembly | Double Check Detector Assembly | Reduced Pressure Assembly |
|----------------------|--|---|--|
| "N" - Shape |  <p>Model 870V</p> |  <p>Model 876V</p> |  <p>Model 880V</p> |
| Vertical |  <p>Model 870V</p> |  <p>Model 876V</p> |  <p>Model 880V</p> |
| Conventional In-Line |  <p>Model 850</p> |  <p>Model 856</p> |  <p>Model 860</p> |

For nearly half a century customers have looked to FEBCO for quality products, reliable low headloss performance, and great value. Today, with the new FEBCO MasterSeries® designs, FEBCO has once again taken the initiative with patented product innovations.

All 2½ through 10" MasterSeries products include:

- Patented VectorCheck performance for low head loss
- Cast ductile iron bodies for lighter weight
- Lowest installed cost — Saves on labor and material
- Choice of cost-saving "N"-Shape designs, revolutionary vertical designs, or conventional in-line designs.

Contact a FEBCO representative today for product literature and technical specifications on FEBCO MasterSeries® backflow prevention products.

WARRANTY

All products manufactured and sold by CMB Industries, Inc. carry with them the following warranty: CMB Industries, Inc. warrants to the original purchaser (who is the end user) all products manufactured by it will be free from defects in workmanship and material for a period of one (1) year from the date of original shipment.

CMB Industries, Inc. also warrants that all internal components of 1/2" through 2" Model 850/860 and 1/2" through 1" Model 766 products, will be free from defects in workmanship and material for a period of five (5) years from the date of original shipment and also that the body only of the 1/2" through 1 1/4" Model 765 will be subject to a lifetime warranty against damage by freezing.

This warranty is applicable provided such products are used under normal conditions within the recognized pressure, flow and temperature limits and are given normal service and care. CMB INDUSTRIES, INC. MAKES NO OTHER REPRESENTATION OR WARRANTY OF ANY KIND, EXPRESSED OR IMPLIED, IN FACT OR IN LAW, AND EXPRESSLY DISCLAIMS ALL OTHER WARRANTIES, INCLUDING WITHOUT LIMITATION, THE WARRANTIES OF MERCHANTABILITY OR FITNESS FOR PARTICULAR PURPOSE. In the event of a defect in material or workmanship of a product covered by this warranty, CMB Industries, Inc. shall, at its sole option, repair or replace such defective product. CMB Industries, Inc. shall not be liable for any labor required to repair or replace any product covered by this warranty. This warranty is void with respect to any such product which is altered or tampered with by anyone without prior consent of CMB Industries, Inc. CMB Industries, Inc. shall not be liable under any circumstances for damages caused by accident, misuse or abuse of the product or for failure to follow the installation, maintenance or operating instructions. IN NO EVENT SHALL CMB INDUSTRIES BE LIABLE FOR INCIDENTAL, INDIRECT, PERSONAL INJURY, PROPERTY OR PUNITIVE DAMAGES.

To make a claim under this warranty, the buyer must notify the factory in writing within ten (10) days of discovery of any claimed defects or workmanship, and if authorized by the factory, shall return the product in the same condition as when received by the buyer, transportation prepaid, to the factory or to such other location as directed by the factory. If said returned product is found by the factory to be defective in workmanship or materials, it shall be repaired or replaced without charge, pursuant to the terms of this warranty. This warranty excludes component parts or appurtenances not manufactured by CMB Industries, Inc. Any claims with respect to such equipment must be made to the manufacturer thereof in accordance with the terms of the warranty, if any, given by such manufacturer, or pursuant to such warranties as may exist by law. The physical or chemical properties of CMB Industries, Inc. products represent typical, average values obtained in accordance with test methods and are subject to normal manufacturing variations. This information is supplied as a technical service and is subject to change without notice.

FEBCO BACKFLOW PREVENTION...

A product of CMB Industries, Inc.

CMB Industries Inc. is a leader in the water control market with more than 75 years of experience in the design and manufacturing of the world's most innovative water control products. CMB Industries products include the FEBCO Backflow Prevention Assemblies, The POLYJET Control Valve, and K-FLO Butterfly Valve.

For more information on how FEBCO Backflow Prevention or other CMB Industries products can meet your specific installation or project need, contact the factory or an authorized representative today.



Post Office Box 8070 • Fresno, California • U.S.A.
Tel# (559) 252-0791 • Fax# (559) 453-9030 • www.cmb-ind.com